



PROVEN PERFORMANCE
SERVICE EXCELLENCE

OUR VALUES

SEC Group have spent the last two decades dedicated to building a reputation in the conveyor industry that is well known and trusted. We are proud to be industry leaders across Australia and one of the largest conveyor companies in South Australia

We work collaboratively with our customers to build relationships that are value-aligned, and long lasting.

With our values of:

- People
- Safety
- Customer Service
- Solution Focussed
- Service Excellence

OUR WORKSHOPS

WORKSHOP CAPABILITIES

Fully equipped and strategically located workshop facilities, means that SEC Group has the capabilities to provide a responsive and complete range of mining equipment maintenance services.

All workshops are fully equipped with the latest technology, tooling and are staffed by trade qualified and experienced personnel.

KEY CAPABILITIES

- Mechanical Repairs & Maintenance
- Engineering Services
- Boilermaking & Fabrication Services
- Wear Management
- Rotable Spares (service, repair and replace)
- Chute manufacture, design & repair
- Conveyor Maintenance
- Conveyor Belt Supply / Install
- Rubber Lining and Pulley Lagging
- Conveyor component sales & maintenance
- Hot and Cold Belt Splicing Repairs





SAFETY

COMPANY PROFILE

Formed in 2000, SEC Group is committed to providing and maintaining a safe and healthy workplace for all employees, suppliers, contractors and visitors.

SEC Group believes occupational health and safety is everyone's responsibility and has designed its health, safety and environment management system (HSEMS) to ensure all responsibilities are clearly outlined to support the importance of leading and promoting the highest principles and practices to ensure health and safety.

At SEC Group, we possess the capacity to offer a comprehensive range of equipment rental, sales, maintenance services for mining, construction, material handling solutions and infrastructure projects.

Our proficient team and ample resources enable us to deliver reliable and effective solutions that meet the expectations of our valued clients.

SERVICE EXCELLENCE

Fully equipped and strategically located workshop facilities, backed by a highly skilled team of technical field staff.

SERVICES

CONVEYOR MAINTENANCE

We offer a skilled and diverse team that takes care of all Conveyor Maintenance requests and requirements.

We excel in providing the following services:

- Spillage Management
- Wear Management
- Repair & Maintenance
- Design & Installation
- Downtime Reduction Strategies
- Predictive Maintenance Strategies

ENGINEERING

With a team of qualified tradespeople, SEC GROUP can offer a diverse range of experience in all areas, specialising in design, drafting, installation, and project management. We have a specialised machine shop with CNC capabilities to complement our engineering, design, and drafting division.

FABRICATION SERVICES

We possess the proficiency to cater to diverse engineering and fabrication needs and ensure that the job is completed to meet our clients' expectations requirements.

Our area of expertise lies in the fabrication of:

- Mild Steel
- Aluminium
- Full CNC Machine Shop
- Stainless Steel
- Structural
- Chutes / Hoppers
- Walkways/ Platforms
- Wear Plates & Chutes
- Mechanical

EQUIPMENT HIRE

We offer a constantly expanding selection of conveyor equipment that is available for hire.

Some examples of these comprise,

- Various Winder capabilities ranging from 7T to 50T,
- Turning frames
- 10T counterweights
- Lap out stands and flaking rollers
- Splicing & Mechanical maintenance containers

We can offer both wet and dry hired to best suit your needs



RELATIONSHIPS

ARE OUR KEY

SEC Group has collaborated with various leading industry companies to provide cutting-edge and top-notch solutions for bulk materials handling. We ensure service excellence and prioritise safety and our people..

OUR CLIENTS



OUR CATALOGUE

PRODUCTS & SERVICES

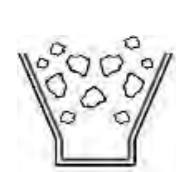

Heavy Wear Lining

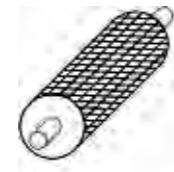

Pulley Lagging



Idlers, Rollers & Frames



Fabric, Steel Cords
Solid Woven, PVC &
Habasit belting

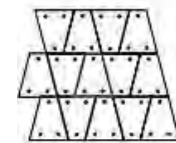

Steel Plates

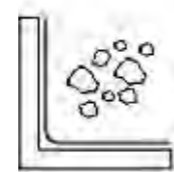

Wear Rubber Lining



Tracking Frames

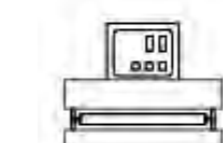

Vulcanisation Presses



Mill Lining



Skirting Systems



Belt Cleaning Systems



Engineering,
Drafting & Design

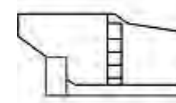

Screening Mats



Ceramics



Pulleys



24/7 Service

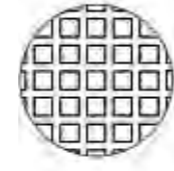

Adhesives

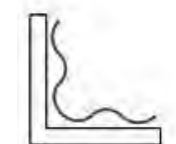

Anti-Caking

OUR BELT SUPPLY



SEC Group is a distributor of a diverse range of Conveyor Belts. Our range has been developed from engineered product designs that have been tested & proven to provide the highest level of product performance in conveying technology.

Our complete independence provides us with the ability to procure specific belts from recognized Australian & International manufacturers that meet the needs of our customers. This ensures the highest level of quality control at the best value.

We can supply belting in cut to width specific lengths, full rolls, vulcanized spliced endless belts, belts joined with mechanical belt fasteners or belts with ends prepared for customer own installation.

We only market conveyor belting produced by belting manufacturers who meet or exceed the applicable Australian Standards.



CHUTE TO CHUTE

CAPABILITIES

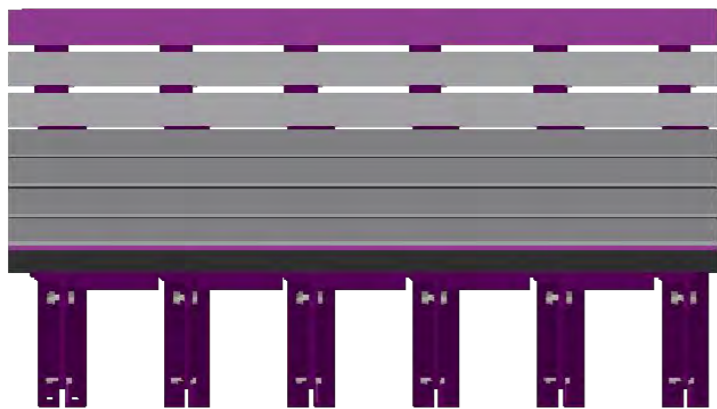

IMPACT BEDS



IDLERS
Standard Roller
Impact Roller
Anti Seize Roller

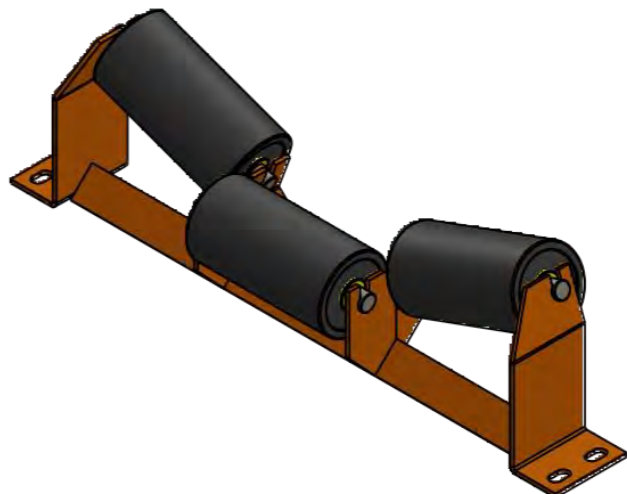

BELT TRACKERS
Roll Flat
Roll V
Roll Trough
Tunner Track

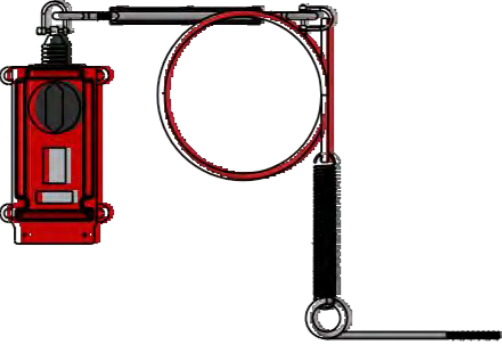

CONVEYOR SAFETY
Safe -T-Switches
Safe -T-Lanyards
Safe -T-Pull
Safe -T-Drift
Safe -T-Rip Detection

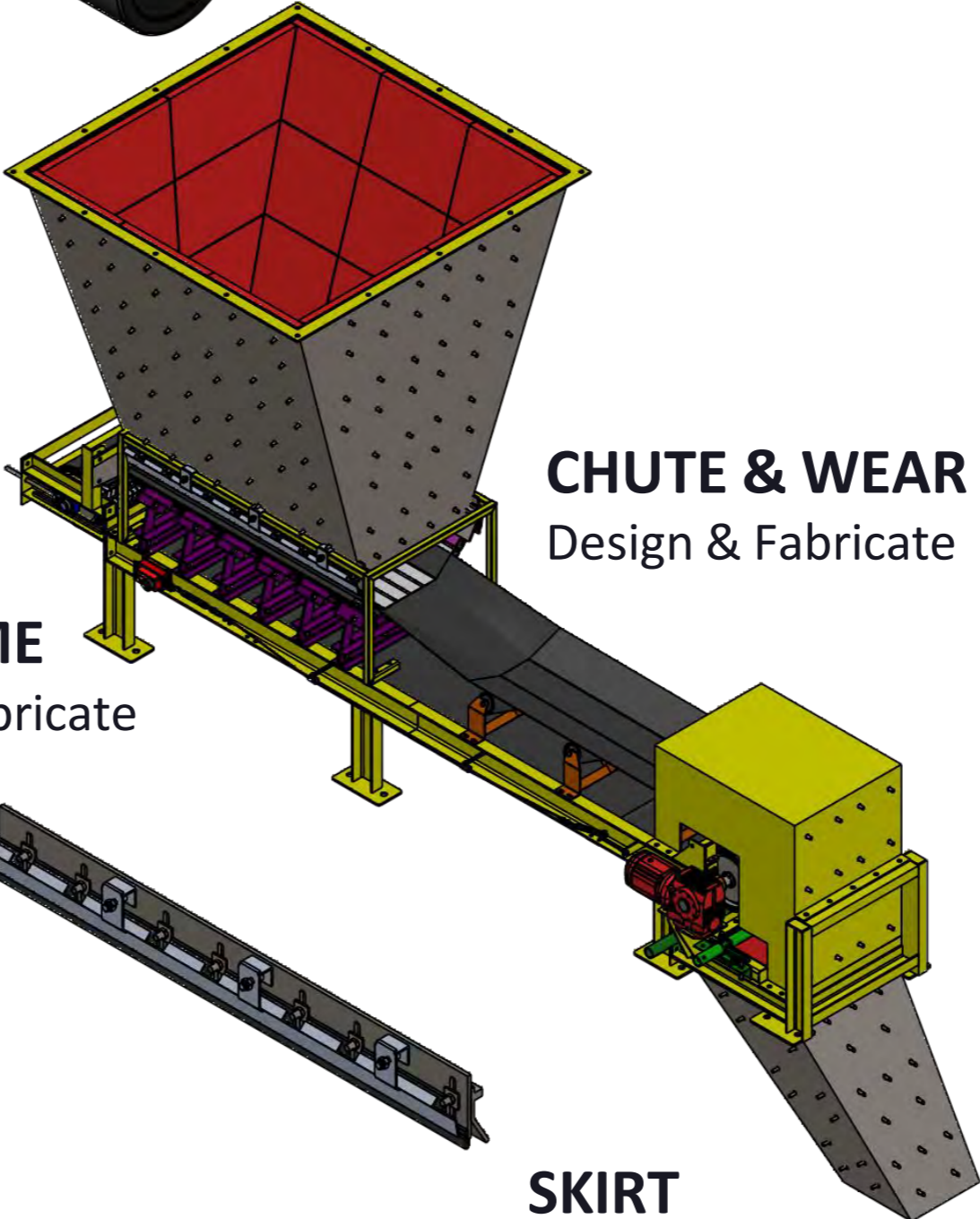

SUB FRAME
Design & Fabricate

CHUTE & WEAR LINER
Design & Fabricate

SKIRT
Sure Clamp
Sure Seal
Sure Fit

PRIMARY CLEANERS

Tungsten Tips
Urethane Tips

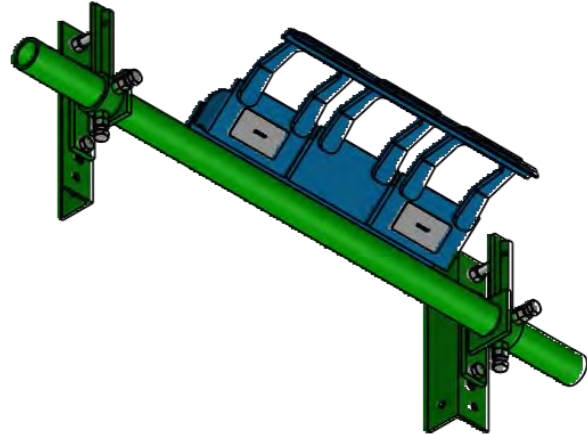

SECONDARY CLEANERS

Tungsten Tips
Urethane Tips

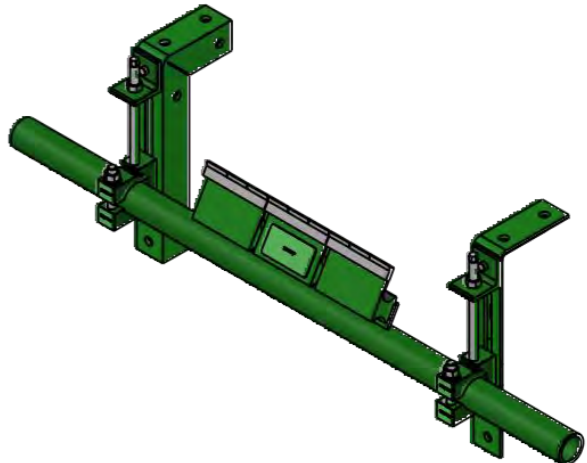

RUBBER
Fabric
Steelcord
Solid Woven
Chevron

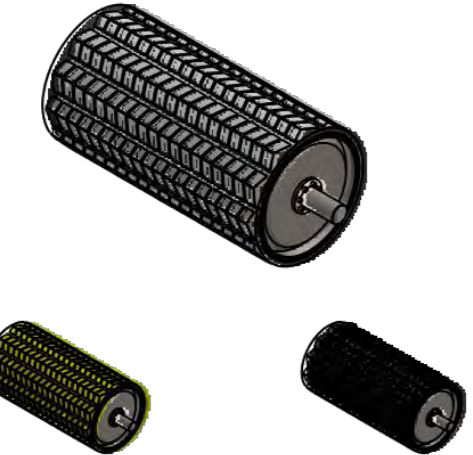

LAGGING
Rubber
Ceramic
Strip Polyurethane
Hot Cast Polyurethane

BEYOND COMPLIANCE

OCCUPATIONAL HEALTH AND SAFETY

SAFETY STRATEGY AND INITIATIVES

1. Maintains its Work Health and Safety Management system to meet ISO 45001:2018
2. Regular reporting and benchmarking of our safety performance against industry standard
3. Safe Work Instructions aligned to national industry training packages including RII09 (Resource and Instructions Industry Training Package)
4. Continuous improvement programs to meet changes in industry and legislative standards

ENVIRONMENTAL

- Compliance with state and federal legislation
- Ensure environmental management forms part of our business planning
- Promote a culture of responsible environmental management

QUALITY ASSURANCE PLAN

- Compliance with legislation
- Provision for the availability of resources
- Maintain an integrated risk register
- Achieve Key Performance Indicators
- Delivering on quality within the work scope
- Adequate training of staff, including contractor management
- Achieving timeframes



Sales Team | SEC Group
08 8349 7818 | sales@sec-group.com.au